

MARSDEN

MARSDEN

Marsden MHS2710 User Manual

Tel: 01709 364296 / 0800 169 2775

Fax: 01709 364293

E-mail: sales@marsdengroup.co.uk

Distribution:

Unit 7, Centurion Business Park,
Coggin Mill Way,
Rotherham, S60 1FB

Head Office:

Unit 1, Genesis Business Park,
Sheffield Road,
Rotherham, S60 1DX

www.marsden-weighing.co.uk

CD-IN-00529 REV001 11/2022

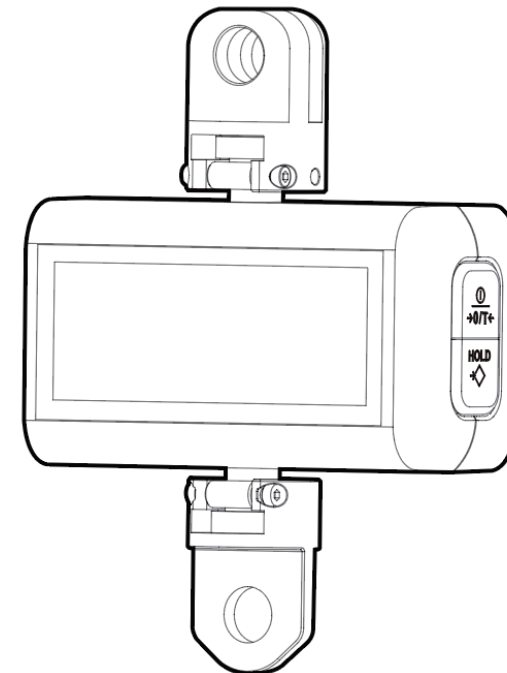

Please keep the instruction manual at hand all the time for future reference.

Contents

Introduction	2
Product Specification	2
Safety Instructions	3
Explanation of Graphic Symbols	5
EMC Guidance and Manufacturer's Declaration	7
Installation	11
Indicator and Key Functions	18
Device Setup	19
Error Messages	22
Technical Data for Joints	23
Declaration of Conformity	24

Introduction

Thank you for purchasing a Marsden professional medical scale. This is a precision Class III weighing instrument and considerate use will result in many years of accurate weighing. The scale has a maximum load capacity of 300kg which must not be exceeded.

Product Specification

Model	MHS2710
Accuracy Class	Class III
Capacity/Division	300 kg x 0.1 kg
Accuracy	±150g
Weight of Scale	1.04 kg
Units of Measure	kg
Function Keys	On/Off/Zero/Tare , Hold
Operating Temperature	0 to +40°C
Power Supply	Rechargeable battery
Indicator Display	1.0-inch LCD screen (5 1/2 digits)

Notes

UKCA Declaration of Conformity

The Non-Automatic Weighing Instrument

III

Manufacturer	Charder Electronic Co., Ltd
Model	MHS2700,MHS2710
Type Examination Certificate No.	T11933-UK

The Metrological Aspects of Non-Automatic Weighing Instruments

EN45501: (module D)	Approved Body Number – 8506
EN45501: (module B)	Approved Body Number – 8506

The non-automatic weighing instrument corresponds to the production model described in the Type Examination Certificate and requirements of the following UK Directives:

S.I. 2016 No.1152	Non-Automatic Weighing Instruments Regulations 2016
-------------------	---

The applicable designated standards are:

EN45501:2015	The Metrological Aspects of Non-Automatic Weighing Machines
EN 60601-1:2006+A11:2011+A1:2013+A12:2014+A2:2021	Medical electrical equipment - Part 1: General requirements for basic safety and essential performance
EN 60601-1-2:2015+A1:2021	Medical electrical equipment - Part 1-2: General requirements for basic safety and essential performance - Collateral Standard: Electromagnetic disturbances - Requirements and tests
(*) ETSI EN 301 489-1 V2.2.3	Electromagnetic compatibility and Radio spectrum Matters (ERM); ElectroMagnetic Compatibility (EMC) standard for radio equipment and services; Part 1: Common technical requirements
(*) ETSI EN 301 489-17 V3.2.4	ElectroMagnetic Compatibility (EMC) standard for radio equipment and services; Part 17: Specific conditions for Broadband Data Transmission Systems; Harmonised Standard for ElectroMagnetic Compatibility
(*) EN 300 328 V2.2.2	Wideband transmission systems; Data transmission equipment operating in the 2,4 GHz band; Harmonised Standard for access to radio spectrum
(*) EN 62479:2010	Assessment of the compliance of low power electronic and electrical equipment with the basic restrictions related to human exposure to electromagnetic fields (10 MHz to 300 GHz)

(*) Standards ETSI EN 301 489-1 V2.2.3, ETSI EN 301 489-17 V3.2.4, EN 300 328 V2.2.2 and EN 62479:2010 are only applicable to the devices with Wireless function.

This declaration of conformity is issued under the sole responsibility of the manufacturer.

Date: 2022.11.03

Signature: Victor Lai

Name:
Position: Measuring Management Rep.
Place: Taichung, Taiwan

Manufacturer: Charder Electronic Co., Ltd.

Address: NO.103, Guozhong Rd., Dali Dist., Taichung City 412, Taiwan

CD-QR00169

Safety Instructions

Before putting the device into use, please read with care the information given in this user manual, which contains important instructions for proper installation, use and maintenance of the device.

Marsden and/or the manufacturer shall not be liable for damages arising from failure to heed the following instructions:

- When using electrical components under increased safety requirements, always comply with appropriate regulations.
- Inappropriate installation/use will render the warranty null and void.
- Ensure the voltage marked on the power supply unit matches your mains supply.
- This device is designed for use indoors only.
- Observe the permissible ambient temperatures for use.
- The device meets the requirements for electromagnetic compatibility. Do not exceed the maximum values specified in the applicable standards.
- Batteries should be kept away from small children. If swallowed, promptly seek urgent medical assistance.
- After assembly at lifter, device must not be rotated horizontally. Rotation should only be conducted by lift system utilizing 360-degree swivel bearing.

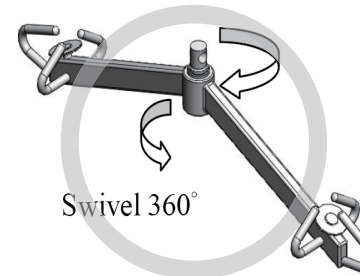

If you have any problems with this scale, please contact Marsden/your local dealer/your service partner.

If a serious incident occurs in relation to this device, it should be reported to the manufacturer and the competent authority of the Member State in which the user and/or patient is established.

Cleaning

- We recommend using alcohol-based wipes or similar when cleaning the scale.
- Please do not use corrosive liquids, large amounts of water or high-pressure washers.
- Always disconnect the scale from the mains power supply before cleaning.

Maintenance

- The scale does not require any routine maintenance. However, we recommend checking the scale's accuracy at regular intervals; frequency to be determined by local metrology/measuring instrument regulations if applicable. If any inaccuracies occur, please contact your local dealer or service partner.
- If any inaccuracies occur, please contact your local dealer or service partner.
- If you are in the UK, service contracts are available from Marsden to keep your scale accurate and reliable for longer. Call 01709 364296 for more information.

Disposing of the Scale

- This product should not be treated as regular household waste but should be handed in to an electrical/electronic equipment recycling centre.
- You can obtain further details from your local council, your municipal waste disposal company or from where you purchased the product.
- Alternatively, you can return this product to Marsden – we will recycle this free of charge,

Intended Use

- This scale is intended for use to determine the weight of patients, supported by professional personnel and in rooms intended for carrying out healthcare. The weighing value can be read after a stable weighing value has been obtained. Before use, the scale must be checked by an authorised person to ensure it's in a suitable condition.
- Device is intended to measure one subject at a time.

charder®

EU Declaration of Conformity

The Non-Automatic Weighing Instrument

III

Manufacturer	Charder Electronic Co., Ltd
Model	MHS2700,MHS2710
EU- type examination Certificate No.	T11933

The Metrological Aspects of Non-Automatic Weighing Instruments

EN45501:2015 (module D)	Notified Body Number – 0122
EN45501:2015 (module B)	Notified Body Number – 0122

The non-automatic weighing instrument corresponds to the production model described in the EU- type examination Certificate and requirements of the following EC Directives:

2014/31/EU	Non-Automatic Weighing Instruments Directive
93/42/EEC as amended by 2007/47/EC	Medical Device Directive
2014/53/EU	Radio Equipment Directive

The applicable harmonized standards are:

EN 45501:2015	The Metrological Aspects of Non-Automatic Weighing Machines
EN 60601-1:2006+A11:2011+A1:2013+A12:2014+A2:2021	Medical electrical equipment - Part 1: General requirements for basic safety and essential performance
EN 60601-1-2:2015+A1:2021	Medical electrical equipment - Part 1-2: General requirements for basic safety and essential performance - Collateral Standard: Electromagnetic disturbances - Requirements and tests
(*) ETSI EN 301 489-1 V2.2.3	Electromagnetic compatibility and Radio spectrum Matters (ERM); ElectroMagnetic Compatibility (EMC) standard for radio equipment and services; Part 1: Common technical requirements
(*) ETSI EN 301 489-17 V3.2.4	ElectroMagnetic Compatibility (EMC) standard for radio equipment and services; Part 17: Specific conditions for Broadband Data Transmission Systems; Harmonised Standard for ElectroMagnetic Compatibility
(*) EN 300 328 V2.2.2	Wideband transmission systems; Data transmission equipment operating in the 2.4 GHz band; Harmonised Standard for access to radio spectrum
(*) EN 62479:2010	Assessment of the compliance of low power electronic and electrical equipment with the basic restrictions related to human exposure to electromagnetic fields (10 MHz to 300 GHz)

(*) Standards ETSI EN 301 489-1 V2.2.3, ETSI EN 301 489-17 V3.2.4, EN 300 328 V2.2.2 and EN 62479:2010 are only applicable to the devices with Wireless function .

This declaration of conformity is issued under the sole responsibility of the manufacturer.

Date: 2022.11.03

Signature:

Victor Lai

Name: Victor Lai
Position: Measuring Management Rep.
Place: Taichung, Taiwan

Manufacturer: Charder Electronic Co., Ltd.
Address: NO.103, Guozhong Rd., Dali Dist., Taichung City 412, Taiwan

CD-QR00139

Declaration of Conformity

FEDERAL COMMUNICATIONS COMMISSION (FCC) STATEMENT

This device complies with Part 15 of the FCC Rules. Operation is subject to the following two conditions:





- 1) This device may not cause harmful interference and
- 2) This device must accept any interference received, including interference that may cause undesired operation of the device.

This product has been manufactured in accordance with the harmonized European standards, following the provisions of the below stated directives:













	(EU) 2017/745 Regulation on Medical Devices Classification: Class I with measuring function
	2014/31/EU Non-automatic Weighing Instruments Directive
	Non-automatic Weighing Instruments Regulations 2016 (S.I. 2016/1152)



RoHS Directive 2011/65/EU and Delegated Directive (EU) 2015/863

Please see separate document showing on sticker of device for above CE marking.

EU Authorized Representative:	 Obelis s.a. Bd Général Wabis, 53 B-1030 Brussels Belgium
UK Authorized Representative:	UK RP: OBELIS UK LTD, Sandford Gate, Oxford, OX4 6LB, UK.
Distributor:	 Marsden Weighing Machine Group Ltd, Unit 1, Genesis Business Park, Sheffield Road, Rotherham, UK, S60 1DX
EU Importer:	 Marsden Weighing Machine Group Europe Ltd, The Black Church, St. Mary's Place, Dublin 7, Dublin, Ireland, D07 P4AX
Manufactured by:	 Charder Electronic Co., Ltd. No.103, Guozhong Rd., Dali Dist., Taichung City 41262, Taiwan

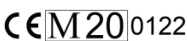
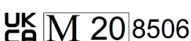
Explanation of Graphic Symbols





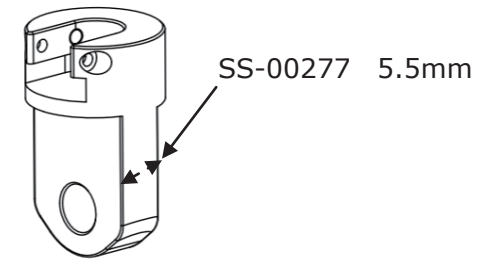
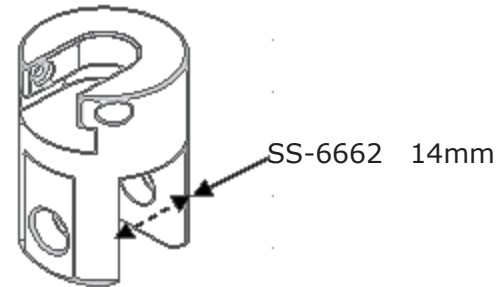
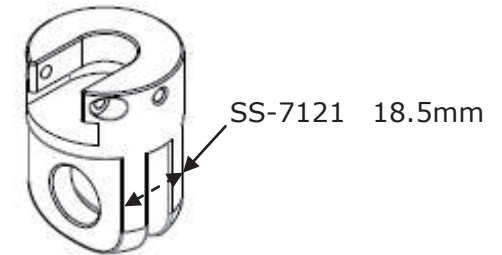
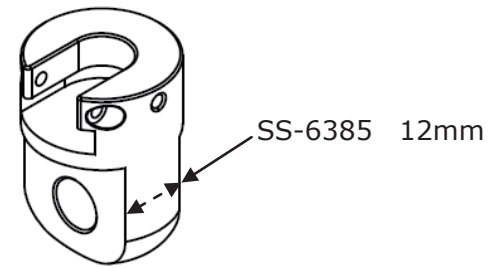
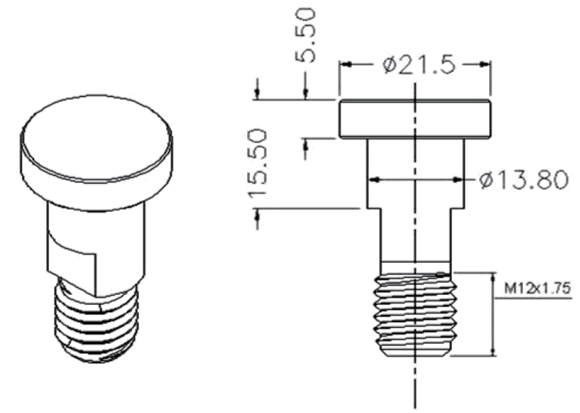

Text/Symbol	Meaning
	Caution, consult accompanying documents before use
	Separate collection for waste of electrical and electronic equipment, in accordance with Directive 2002/96/EC. Do not dispose of device with everyday waste
	Name and address of device manufacturer, and year/country of manufacture
	Carefully read user manual before installation and usage, and follow instructions for use.
	Medical electrical device, Type B applied part
	Device catalogue number / model number
	Name and address of authorized representative in the European Union
	Device is a medical device. Text indicates device category type
	Manufacturer's batch or lot number for device
	Device's serial number
	Device's Unique Device Identifier
	Value in mass units (verified models only). This is the difference between two consecutive display values, used to classify and verify a scale
	Device conforms to (EU) 2017/745 Regulation on Medical Devices. Four digit number is identifier for medical device Notified Body
	Device complies with EC directives (verified models only) M :Conformity label in compliance with Directive 2014/31/EU for non-automatic weighing instruments 20 :Year in which conformity verification was performed and the CE label was applied. (ex: 20=2020) 0122 : Identifier for metrology Notified Body
	Device complies with UK directives (verified models only) M : Conformity label in compliance with Non-automatic Weighing instruments Regulations 2016 20 : Year in which conformity verification was performed and the UKCA label was applied. (ex: 20=2020) 8506 :Identifier for metrology Notified Body

III	Device is a Class III scale in compliance with Directive 2014/31/EU (verified models only)
	Name and address of entity importing device (if applicable)
	Name and address of entity responsible for translating Information For Use (if applicable)
CON.	Event counter confirming how many times device has been calibrated (if applicable)

Technical Data for Joints

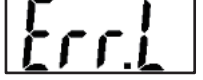
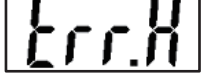

Error Messages

Error Message	Reason	Action
	Low battery warning Voltage of battery is too low to operate device	Replace batteries
	Overload Total load exceeds device's maximum capacity	Reduce weight on measurement platform and try again
	Counting Error Signal from loadcells too low	Error normally caused by faulty loadcell or wiring. Please contact distributor
	Counting Error Signal from loadcells too high	Error normally caused by faulty loadcell or wiring. Please contact distributor
	Zero count over calibration zero range +10% while power on	Re-calibration required. Please contact distributor
	Zero count under calibration zero range -10% while power on	Re-calibration required. Please contact distributor
	Program Error Fault with device software	Please contact distributor

EMC Guidance and Manufacturer's Declaration

Guidance and manufacturer's declaration-electromagnetic emissions		
The MHS2710 Lift Scale is intended for use in the electromagnetic environment specified below. The customer or the user of the device should assure that it is used in such an environment.		
Emission test	Compliance	Electromagnetic environment-guidance
RF emissions CISPR 11	Group 1	The device uses RF energy only for its internal function. Therefore, its RF emissions are very low and are not likely to cause any interference in nearby electronic equipment.
RF emissions CISPR 11	Class B	The device is suitable for use in all establishments, including domestic establishments and those directly connected to the public low-voltage power supply network that supplies buildings used for domestic purposes.
Harmonic emissions IEC 61000-3-2	Class A	
Voltage fluctuations /flicker emissions IEC 61000-3-3	Compliance	

Guidance and manufacturer's declaration-electromagnetic immunity			
The MHS2710 Lift Scale is intended for use in the electromagnetic environment specified below. The customer or the user of the device should assure that it is used in such an environment.			
Immunity test	IEC 60601 test level	Compliance level	Electromagnetic environment-guidance
Electrostatic discharge(ESD) IEC 61000-4-2	<u>± 8 kV contact</u> <u>± 2 kV, ± 4 kV, ± 8 kV, ± 15 kV air</u>	<u>± 8 kV contact</u> <u>± 2 kV, ± 4 kV, ± 8 kV, ± 15 kV air</u>	Floors should be wood, concrete or ceramic tile. If floors are covered with synthetic material, the relative humidity should be at least 30%

Electrical fast transient/burst IEC 61000-4-4	± 2kV for power supply lines + 1kV for input/output lines	+ 2kV for power supply lines + 1kV for input/output lines	Mains power quality should be that of a typical commercial or hospital environment.
Surge IEC 61000-4-5	± 1kV line(s) to line(s) ± 2kV line(s) to earth	+ 1kV line(s) to line(s) + 2kV line(s) to earth	Mains power quality should be that of a typical commercial or hospital environment.
Voltage Dips, short interruptions and voltage variations on power supply input lines IEC 61000-4-11	<u>0% UT for 0,5 cycle</u> <u>0% UT for 1 cycle</u> <u>70% UT(30% dip in UT) for 25 cycles</u> <u>0% UT for 5 s</u>	<u>0% UT for 0,5 cycle</u> <u>0% UT for 1 cycle</u> <u>70% UT(30% dip in UT) for 25 cycles</u> <u>0% UT for 5 s</u>	Mains power quality should be that of a typical commercial or hospital environment. If the user of the device requires continued operation during power mains interruptions, it is recommended that the device be powered from an uninterruptible power supply or a battery.
Power frequency(50/60 Hz) magnetic field IEC 61000-4-8	<u>30 A/m</u>	<u>30 A/m</u>	The device power frequency magnetic fields should be at levels characteristic of a typical location in a typical commercial or hospital environment.
NOTE UT is the a.c. mains voltage prior to application of the test level.			

Guidance and manufacturer's declaration-electromagnetic immunity			
The MHS2710 Lift Scale is intended for use in the electromagnetic environment specified below. The customer or the user of the device should assure that is used in such an environment.			
Immunity test	IEC 60601 test level	Compliance level	Electromagnetic environment-guidance
Conducted RF IEC 61000-4-6	3 Vrms 150 KHz to 80 MHz	3 Vrms 150 KHz to 80 MHz	Portable and mobile RF communications equipment should be used no closer to any part of the device including cables, than the recommended separation distance calculated from the equation applicable to the frequency of the transmitter.
Radiated RF IEC 61000-4-3	<u>6 V in ISM bands between 0,15 MHz and 80 MHz</u> <u>80 % AM at 1 kHz</u> 3 V/m 80MHz to 2,7 GHz	<u>6 V in ISM bands between 0,15 MHz and 80 MHz</u> <u>80 % AM at 1 kHz</u> 3 V/m 80MHz to 2,7	

Wireless Connection

If the device has wireless module installed, it will be activated automatically when device is turned on. Please see MARSDEN wireless software instructions for details.

Troubleshooting

Before contacting your local MARSDEN distributor for repair service, we recommend considering the following troubleshooting procedures:

Self-inspection

1. Device will not power on

- If battery power is depleted, replace with new batteries

2. Indicator showing "00000" ZERO SPAN out of range

- Interference due to factors such as RF disturbance or ground vibration. Relocate device to location without interference and try again
- External objects interfering with device. Clear area of interfering objects and try again
- If the steps above cannot resolve the problem, re-calibration may be required to correct weighing accuracy

Distributor support required

If the following errors occur, we recommend contacting your local MARSDEN distributor for repair or replacement services:

1. Device will not power on

- Faulty on/off key
- Broken or damaged wires causing short circuit or faulty connection
- Safety fuse burnout

2. Indicator damage

- Possible hardware defects include: uneven brightness in LCD screen, blurred text, smeared rainbow screen, incorrect decimal display
- Unable to save or read data
- Indicator shows "ErrL" after device is switched on
- Keys not responding
- Buzzer malfunction

Using Device

A. Basic Operation

Switch on the device using  key. The device will automatically perform self-calibration, displaying software version.

Once "0.00 kg" appears on indicator, device is ready for measurement.

Note: If "0.00 kg" does not display on indicator, press  key to zero the device.

Guide subject to sit upon sling (or other device connected to lift). After the weight has stabilized, the "stable" symbol will appear on indicator.

Note: If subject's weight exceeds scale capacity (including tare), indicator will display "Err" prompt due to overload.

B. Hold

The hold function determines average weight, designed to be used if subject's weight will not stabilize (ex: an active child).

Note: if fluctuation is too severe, average weight determination will be difficult and hold may not function correctly

1. Switch on the device normally.

2. Press the  key. "HOLD" will be displayed on the indicator.

3. Conduct measurement as usual.

4. After a few seconds, the average weight will be displayed on the indicator. This weight will be locked - at this point, subject movement will not affect weight.

5. To release the locked weight, press the  key again to return to the device to normal mode.

Note: Hold function can be activated before or after subject sits in sling.

C. Tare

The tare function allows the user to deduct the weight of objects from the device's measurement result.

1. Place object that needs to be tared onto sling.

2. Press  key after stable symbol appears on indicator. Display will indicate "0.00 kg".

3. Guide subject (plus tared object) to be weighed upon sling. Conduct measurement.

4. To clear tare value, remove all objects from sling, and press  key.

		<p>GHz</p>	<p>Recommended separation distance:</p> <p>$d = 1,2 \sqrt{P}$</p> <p>$d = 1,2 \sqrt{P}$ 80MHz to 800 MHz</p> <p>$d = 2,3 \sqrt{P}$ 800MHz to 2,5 GHz</p> <p>Where P is the maximum output power rating of the transmitter in watts (W) according to the transmitter manufacturer and d is the recommended separation distance in metres (m).</p> <p>Field strengths from fixed RF transmitters, as determined by an electromagnetic site survey^a, should be less than the compliance level in each frequency range^b.</p> <p>Interference may occur in the vicinity of equipment marked with the following symbol:</p> 
<p>NOTE1 At 80 MHz and 800 MHz, the higher frequency range applies.</p> <p>NOTE2 These guidelines may not apply in all situations. Electromagnetic propagation is affected by absorption and reflection from structures, objects and people.</p>			
<p>a Field strengths from fixed transmitters, such as base stations for radio (cellular/cordless) telephones and land mobile radios, amateur radio, AM and FM radio broadcast and TV broadcast cannot be predicted theoretically with accuracy. To assess the electromagnetic environment due to fixed RF transmitters, an electromagnetic site survey should be considered. If the measured field strength in the location in which the device is used exceeds the applicable RF compliance level above, the device should be observed to verify normal operation. If abnormal performance is observed, additional measures may be necessary, such as re-orienting or relocating the device.</p> <p>b Over the frequency range 150 kHz to 80 MHz, field strengths should be less than 3 V/m.</p>			

Recommended separation distance between portable and mobile RF communications equipment and the MHS2710 Lift Scale

The device is intended for use in an electromagnetic environment in which radiated RF disturbances are controlled. The customer or the user of the device can help prevent electromagnetic interference by maintaining a minimum distance between portable and mobile RF communications equipment (transmitters) and the device as recommended below, according to the maximum output power of the communications equipment.

Rated maximum output power of transmitter W	Separation distance according to frequency of transmitter m		
	150 kHz to 80 MHz $d = 1,2\sqrt{P}$	80 MHz to 800 MHz $d = 1,2\sqrt{P}$	800 MHz to 2,5 GHz $d = 2,3\sqrt{P}$
0,01	0,12	0,12	0,23
0,1	0,38	0,38	0,73
1	1,2	1,2	2,3
10	3,8	3,8	7,3
100	12	12	23

For transmitters rated at a maximum output power not listed above, the recommended separation distance d in metres (m) can be estimated using the equation applicable to the frequency of the transmitter, where p is the maximum output power rating of the transmitter in watts (W) according to the transmitter manufacturer.

NOTE1 At 80 MHz and 800 MHz, the separation distance for the higher frequency range applies.

NOTE2 These guidelines may not apply in all situations. Electromagnetic propagation is affected by absorption and reflection from structures, objects and people.

Device Setup

When the device is switched on, press and hold the  key for about 3 seconds, until the display shows the "SETUP", followed by "A_OFF" (first option in setting menu).



In device setup menu:



to toggle next menu option





to confirm selection / enter submenu

After changes are complete, press  until "End" appears on screen. Press  to save changes. Device will automatically restart and apply changes.

Auto Power-Off: 

Instruct device to shut off automatically after a certain period of time.



Auto off options: 60 sec / 120 sec / 180 sec / 240 sec / 300 sec / off

Press  to toggle between time options, and  to confirm selection.

g noise will

Buzzer/Beep: 



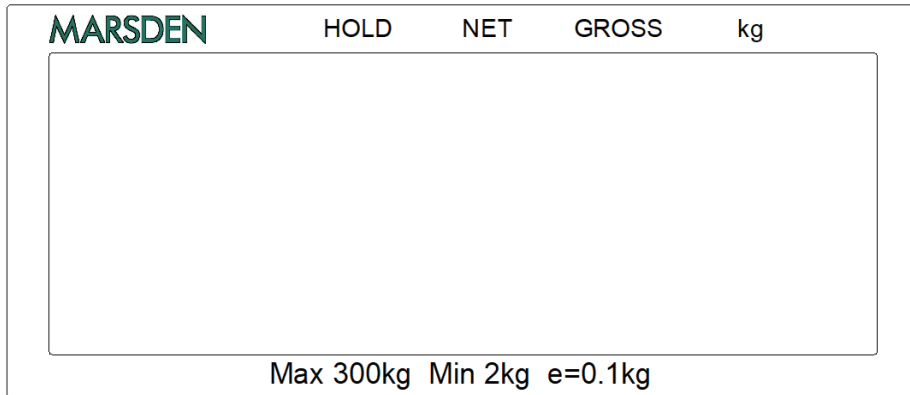

When function is turned on, beeping noise will be made when: indicator is turned on, keys are pressed, and weight is stable.

Press  to toggle between on/off, and  key to confirm selection.

Indicator and Key Functions



Display

-  : Wireless
-  : Stable
-  : Negative weight
-  : Zero
-  : Battery

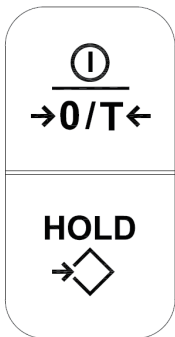

Key Function (2-key model)

1.  →0/T←: Power on or power off. Reset display to 0.0 kg display (can be used if within $\pm 2\%$ of full capacity). Press and hold for 3 seconds to turn off.
2. HOLD: Determine stable weighing value - used when weight is unstable. Press and hold for 3 seconds to enter settings.

Installation

A. Safety Warnings

Lift Scale must NOT tilt at any time

1. Lift scale must NOT tilt when installed on Patient Lift System.

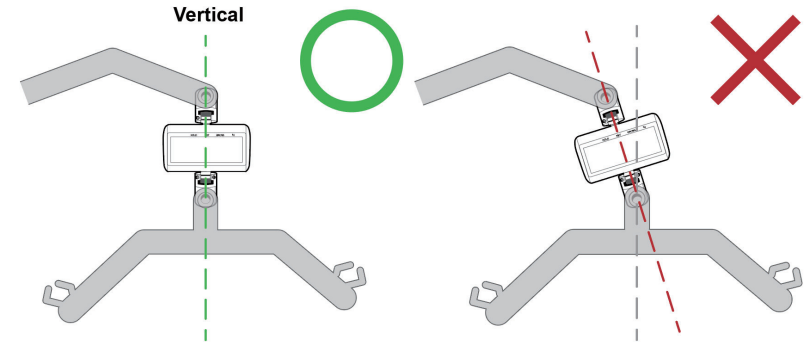

If Lift Scale is tilted and not completely vertical when installed, this will cause the joints of the Lift Scale to bend. This will eventually cause breakage once used enough times and subjected to enough weight, because force is being applied against joints in a way that they aren't designed to handle.

2. Lift Scale must NOT tilt at any time during Patient Lift System's operation.

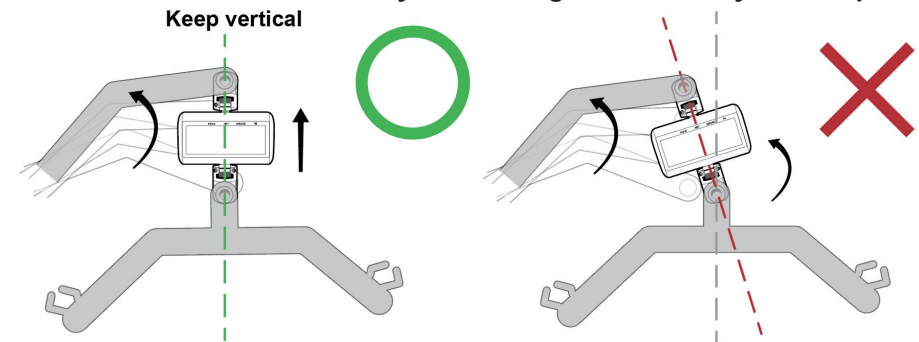

Even if Lift Scale is completely vertical when installed, if it is bent at any point in operation (ex: Patient Lift System raises patient to higher point for weight measurement), the same risk of breakage applies.

IMPORTANT: If tilt or bending is observed at any time, the Lift Scale must NOT be used.

Inspect cardan joints before use for signs of damage or looseness

1. Inspect cardan joints connecting Lift Scale to Patient Lift System visually before use.

The Lift Scale is designed to be installed between the lifting bar and hanger of the Patient Lift System, in a completely vertical position.

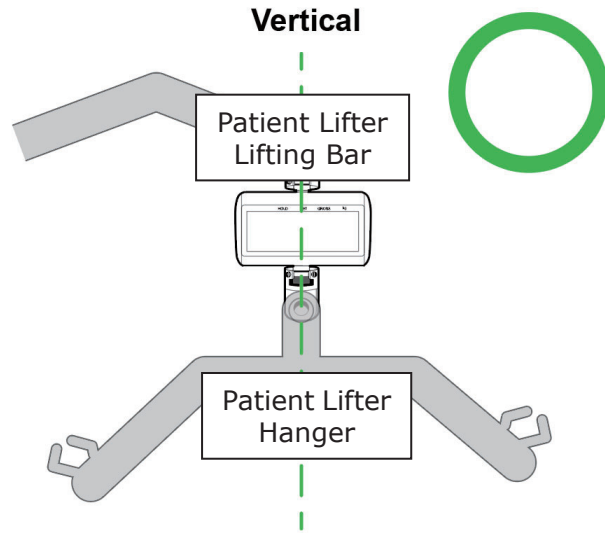

Both top and bottom cardan joints should be inspected for bending.

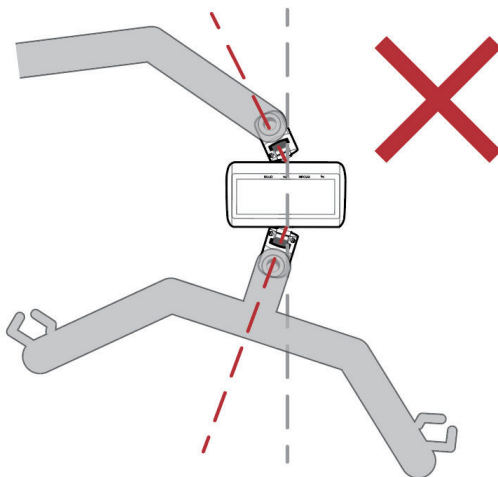

If any visual damage or bending is observed, do NOT use Lift Scale.

B. Inserting Batteries

The device utilizes a rechargeable battery pack.

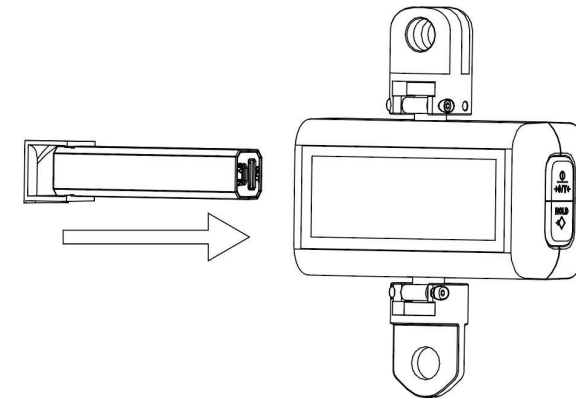

When power is low, please recharge the battery pack using the micro-USB port. When the port light is blinking **red**, battery is being charged. When the port light is stable **green**, battery is fully charged.

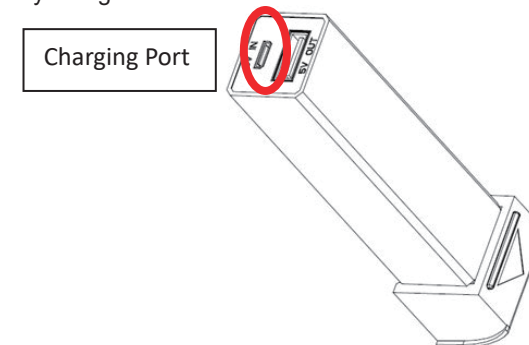

IMPORTANT (SAFETY NOTICE):

- Charging should only be done with approved MARSDEN charger.
- Charging should be performed in a fire-safe area, away from children or pets.
- Charging should be performed at a temperature between **10°C and 45°C**. Never charge batteries unattended, or where objects such as carpet, furniture, wood or vinyl floors, curtains or other flammable objects are present.
- Do not attempt to charge a battery that is swollen or bulging.
- Batteries should be stored in a cool and dry place when not in use.
- If used frequently, batteries can be stored at full charge. However, to maximize battery life, infrequently batteries should not be stored at full charge.
- Batteries in long-term storage should be fully charged every three months or ago to avoid depletion and battery damage.

Check to ensure all screws are fully tightened

No.	Item	Qty
A	Hexagon Nylock screw	2 screws per joint
B	Stopper screw	1 screw per joint

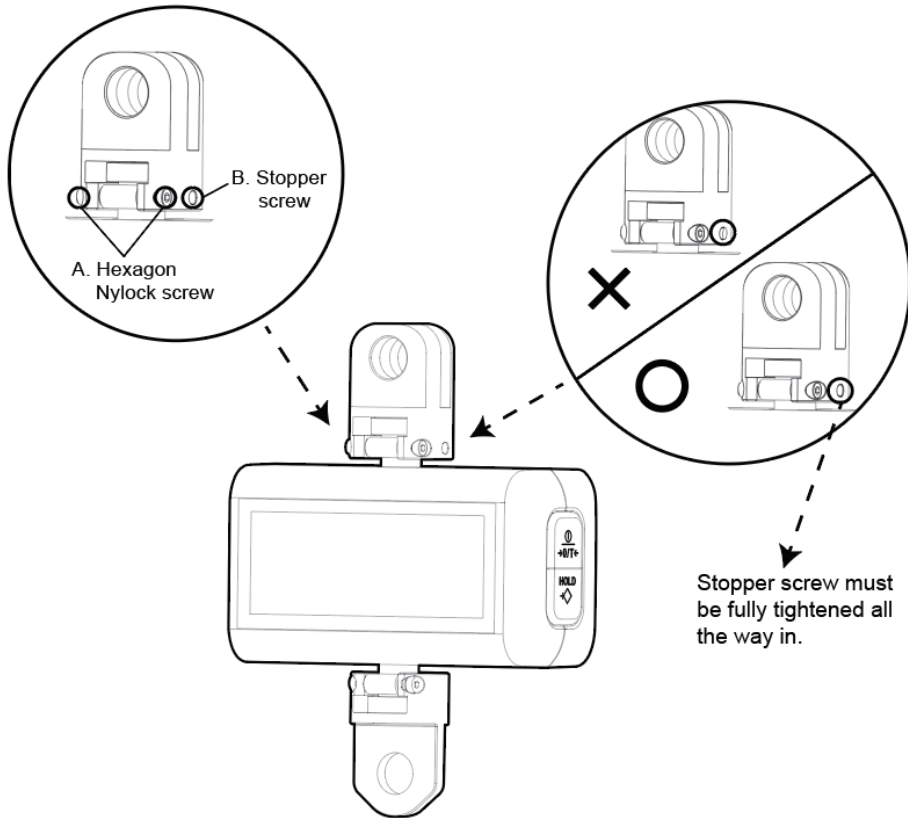

2. If no visual damage is observed, the Lift Scale should be twisted manually to test if incorrect movement is possible.

MARSDEN Lift Scales should be installed on Patient Lift Systems utilizing 360-degree swivel bearings. Rotation should be conducted using **Lift System**, rather than device.

The cardan joints on MHS2700 Lift Scales (with **fixed** cardan joints) do NOT swivel. If they can be manually twisted, that means the joints are damaged, and the Lift Scale should NOT be used.

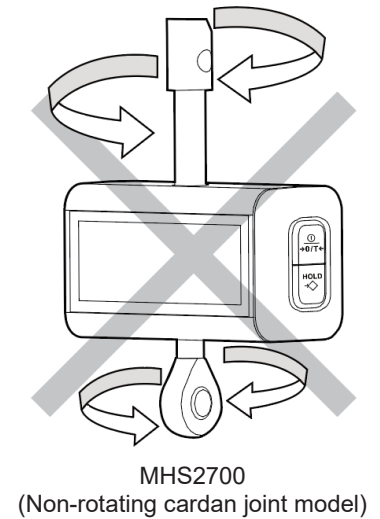
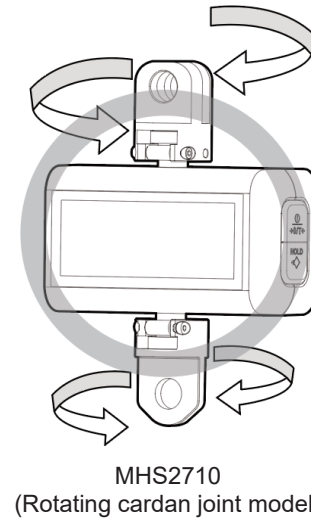

The cardan joints on MHS2710 Lift Scales (with **rotating** cardan joints) will swivel, but only **horizontally**. If they can be manually twisted in any other direction, that means joints are damaged, and the Lift Scale should NOT be used.

3. Lift Scale and hanger bar must be allowed free movement in all directions.

If Lift Scale is obstructed from free movement, twisting force will be applied to Lift Scale, potentially causing damage.

Lift Scale should be installed on Patient Lift System that allows 360-degree free swivel

1. Rotation should be conducted by 360-degree free swivel Patient Lift System.

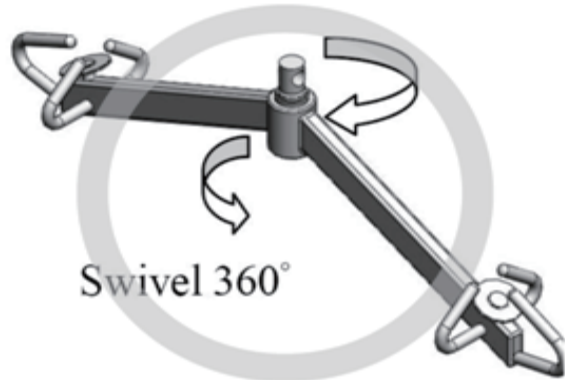

Even if the MHS2710 Lift Scales with horizontally-rotating cardan joints are used, rotation should be conducted by the Patient Lift System, and not the Lift Scale, to minimize risk of damage to Lift Scale.

Nylock Screws must be screwed in tightly according to specifications

Nylock Screws must be secured according to correct assembling procedure. Prepare one hexagon screwdriver and one torque wrench.

1. Hold/fix one side using screwdriver
2. Tighten/attach Nylock Screws using torque wrench (repeat from other side)

IMPORTANT: Torque strength must be set at 18kgf-cm ± 1kgf-cm

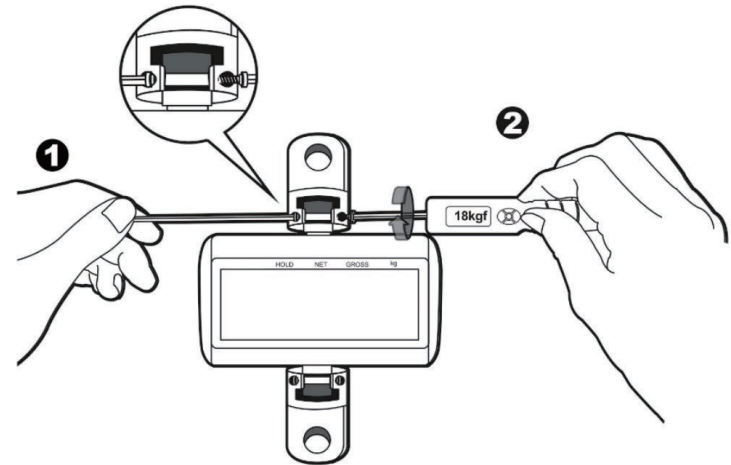

IMPORTANT: Nylock Screw must be secured from both sides (one side with screwdriver, other side by torque wrench). Nylock Screw will not tighten, and will simply rotate in place if counter-force from other side is not applied.

